

TEC-6400 DIN RAIL Temperature Controller



Design Features

- * DIN Rail Mount, 35 mm
- * Fuzzy modified PID heat and cool control
- * Universal input (TC, PT100, mA, V) with high accuracy 18-bit D-A
- * Countdown display
- * RS - 485 and Analog Retransmission Available
- * Micro USB Programming Port
- * Fast sampling rate (200 msec)
- * Manual control & auto-tune function
- * Wide range of alarm mode selection
- * Lockout protection
- * Bumpless transfer during failure mode
- * Soft-start ramp & dwell timer
- * Bright LCD display stabilized with digital filter
- * High performance with low cost

Agency Approvals:



RoHS, REACH, WEEE

Hardware Code: TEC-6400 - 1 2 3 4 5

A Part Number based on the hardware code and any software pre-programming will be issued at time of order.

Standard lead time is stock to 2 weeks.

Power Input BOX 1

- 4** = 90-250 VAC
- 5** = 11-40 VDC / 20-28 VAC

Output 1 BOX 2

- 1** = Relay: 2A / 240 VAC
- 2** = Pulse DC for SSR drive: 5 VD (30 mA max)
- 3** = Isolated, 4-20 mA (default), 0-20 mA
- 5** = Isolated VDC, 0-10 scalable
- C** = Pulse DC for SSR drive: 14 VDC (40mA max)

Output 2 / Alarm 1 BOX 3

- 0** = None
- 1** = Relay: 2A / 240 VAC
- 2** = Pulse DC for SSR drive: 5 VDC (30 mA max)
- 3** = Isolated, 4-20 mA (default), 0-20 mA
- 5** = Isolated, VDC, 0-10 scalable
- C** = Pulse DC for SSR drive: 14 VDC (40mA max)

Option 1 BOX 4

- 0** = None
- 1** = RS-485 Interface
- 2** = 1 Event Input EI 1
- 3** = 1 CT Input (CT 1)

Option 2 BOX 5

- 0** = None
- 1** = Retransmit: 4-20mA / 0-20mA
- 2** = Retransmit: 0-10 VDC
- 3** = Alarm 2 Relay: 2A / 240 VAC
- 4** = 1 Event Input EI 2
- 5** = 1 CT Input (CT 2)

*Transformer for
Heater Break Alarm
(0-50 Amp current)
Part Number: TEC99998*

SOUTHWEST HEATER AND CONTROLS

10610 Control Place, Dallas Texas 75238

Main# 214-340-7500

Toll Free#: 800-687-2220

EMAIL: sales@swhc.com

WEB: www.swhc.com

TEC-6400 Specifications

Power Input

Standard: 90-250 VAC, 47-63 Hz, 8VA, 4W maximum
Optional: 11-40 VDC / 20-8 VAC, 47-63 Hz, 8VA, 4W maximum

Signal Input

Resolution: 18 Bits
Sampling Rate: 5 Times / Second (200msec)
Maximum Rating: -2VDC minimum, 12VDC maximum
Sensor Break Detection: Sensor open for thermocouple and RTD inputs, sensor short for RTD input, below 1mA for 4-20mA input, below 0.25V for 1-5V input, not available for other inputs
Sensor break responding time: Within 4 seconds for thermocouple and RTD inputs, 0.1 second for 4-20mA and 1-5V inputs

Event Input

Number of Event Inputs: 1
Logic Low: -10V minimum, 0.8V maximum
Logic High: 2V minimum, 10V maximum

CT Input

CT type: CT98-1
Accuracy: $\pm 2\%$ of full scale reading, ± 1 digit maximum
Input Impedance: 294 Ω
Measurement Range: 0-50A AC
Output of CT: 0-5V DC
CT Mounting: Wall (Screw) mount
Sampling Rate: 1 time/second

Output 1 / Output 2

Type: Relay, pulsed voltage, linear voltage and linear current
Relay Rating: 2A, 240V AC, 200000 life cycles for resistive load
Pulsed Voltage: Source voltage 5V, Current limiting resistance 66 Ω
Linear Output Resolution: 15 Bits
Isolation Breakdown Voltage: 1000 V AC
Load Capacity of Linear Output: Linear current: 500 Ω maximum, Linear voltage: 10K Ω minimum

Alarm

Relay Type: Form A
Maximum Rating: 2A, 240VAC, 200000 life cycles for resistive load
Alarm Functions: Dwell timer, Deviation low, Deviation high, Deviation band low, Deviation band high, Process high, Process low
Alarm Mode: Latching, Hold, Normal, Latching/Hold
Dwell Timer: 0.1-4553.6 minutes

Data Communications

Interface: RS-485
Protocol: Modbus RTU
Address: 1-247
Baud Rate: 2.8 - 115.2 Kbits/sec
Parity Bit: None, Even or Odd
Stop Bit: 1 or 2 Bits
Data Length: 7 or 8 Bits
Communication Buffer: 160 bytes

Output Signal: 4-20 mA, 0-20 mA, 0-10V
Resolution: 15 Bits
Accuracy: $\pm 0.05\%$ of span $\pm 0.0025\%$ / $^{\circ}\text{C}$
Load Resistance: 0-500 Ω for current output, 10K Ω minimum for voltage output
Isolation Breakdown: 1000VAC minimum
Linear Output Ranges: 0-22.2mA (0-20mA / 4-20mA), 0-5.55V (0-5V, 1-5V), 0-11.1V (0-10V)

User Interface

Keypad: 4 Keys
Display Type: 4 digit LCD display
No. of Display: 2
Upper Display Size: 0.31" (8mm)
Lower Display Size: 0.25" (6.5mm)

Programming Port

Interface: Micro USB
PC Communication Function: Automatic Setup, Calibration and Firmware Upgrade

Control Mode

Output 1: Reverse (Heating) or Direct (Cooling) Action
Output 2: PID cooling control, Cooling P band 50-300% of PB, Dead band -36.0 ~ 36.0 % of PB
ON-OFF: 0.1-90.0 ($^{\circ}\text{F}$) hysteresis control (P band = 0)
P or PD: 0-100.0 % offset adjustment
PID: Fuzzy logic modified Proportional band 0.1 ~ 900.0 $^{\circ}\text{F}$, Integral time 0-3600 seconds, Derivative time 0-360.0 seconds
Cycle Time: 0.1-90.0 seconds
Manual Control: Heat (MV1) and Cool (MV2)
Failure Mode: Auto transfer to manual mode while sensor break or A-D Converter damage
Ramping Control: 0 to 900.0 $^{\circ}\text{F}$ / Minute or 0 to 900.0 $^{\circ}\text{F}$ / Hour Ramp Rate

Environmental and Physical Specifications

Operating Temperature: -10 $^{\circ}\text{C}$ to 50 $^{\circ}\text{C}$
Storage Temperature: -40 $^{\circ}\text{C}$ to 60 $^{\circ}\text{C}$
Humidity: 0 to 90 % RH (Non-Condensing)
Insulation Resistance: 20M Ω minimum (@500V DC)
Dielectric Strength: 2000V AC, 50/60 Hz for 1 Minute
Vibration Resistance: 10 to 55 Hz, 10m/s² for 2 Hours
Shock Resistance: 200 m / s² (20g)
Moldings: Flame retardant polycarbonate
Mounting: DIN Rail, 35 mm
Dimensions W x H x D: 3-3/4 x 7/8 x 3-11/16" (96 x 22.5 x 83 mm)
Depth Behind Panel (mm): n/a
Cut Out Dimensions (mm): n/a
Weight: .35 lbs. (160 g)

Rear Terminal Connections

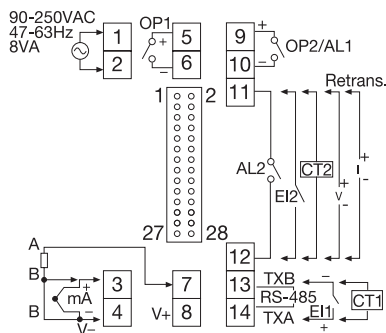

Stock and Common Part Numbers

(All Stock Part Numbers Include Terminal Covers)
 (Default Type "J" Thermocouple Input)

Part Number	Output 1	Out 2/ Alm 1	Option 2
TEC80001	Relay	None	None
TEC80002	Relay	Relay	None
TEC80003	Relay	Relay	Relay
TEC80004	Pulse DC	None	None
TEC80005	Pulse DC	Relay	None
TEC80006	Pulse DC	Relay	Relay
TEC80007	4-20mA	none	none
TEC80008	4-20mA	Relay	Relay

SOUTHWEST HEATER AND CONTROLS

10610 Control Place, Dallas Texas 75238

Main# 214-340-7500

Toll Free#: 800-687-2220

EMAIL: sales@swhc.com

WEB: www.swhc.com